

GR. NAPOLES 8.4

WARDROBE NAPOLES 8.4
ROPERO NAPOLES 8.4

ESQUEMA DE MONTAGEM 946040

ASSEMBLING INSTRUCTIONS
MANUAL DE ARMADO

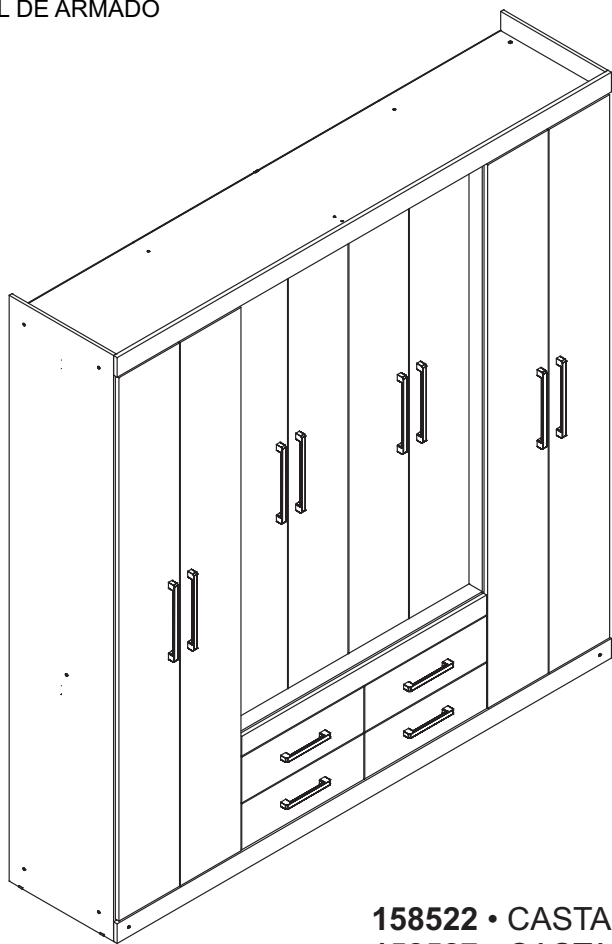

santos
Andirá



ESCANEE O QR CODE
OU CLIQUE AQUI PARA
RESPONDER A PESQUISA



120 minutos
120 minutes

158522 • CASTANHA/CASTANHA
158527 • CASTANHA/OFFWHITE
158543 • JATOBA/AREIA
158544 • JATOBA/JATOBA
158548 • JATOBA/GRAFITTE
158555 • ATACAMA/ATACAMA
158566 • BRANCO/BRANCO

www.santosandira.com.br

01

AVISO

Para limpeza do seu móvel utilize flanela seca ou levemente umedecida, sem produtos químicos!

WARNING

To clean your mobile use dry cloth or slightly moistened, no chemicals!

ADVERTENCIA

Para limpiar su mueble use un paño seco o ligeramente humedecido, sin productos químicos!



ISO 9001



ISO 14001



Descarte os resíduos de forma seletiva!

Dispose of waste selectively!

¡Deseche los residuos de manera selectiva!

Em caso de produto com espelho siga as instruções abaixo:

In the case of a product with a mirror, follow the instructions below

En el caso de un producto con espejo, siga las instrucciones a continuación:

Cole os espelhos na porta e aguarde cerca de 01 hora para fazer a colocação da mesma no produto.

Attach the mirrors to the door and wait about 01 hour to place it on the product.

Coloque los espejos en la puerta y espere alrededor 01 hora para colocarlos sobre el producto.

02

O peso máximo da carga exibido no desenho refere-se a objetos distribuídos de maneira uniforme sobre toda a área de contato da peça.





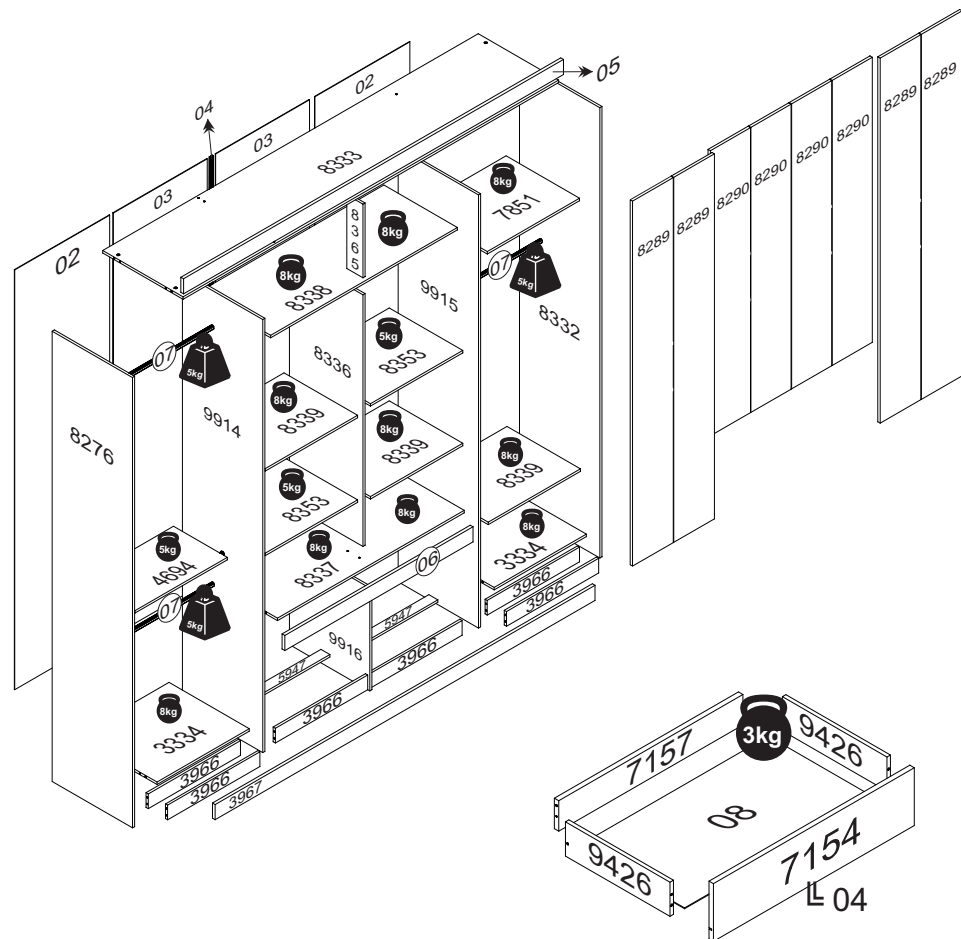





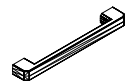









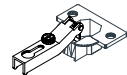

The maximum loading weight the image shows refers to objects distributed uniformly over the whole part contact area.

El peso máximo de carga informado en el diseño se refiere a objetos distribuidos uniformemente sobre totalidad de la área de contacto de la pieza.

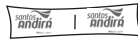

TOTAL DE PESO SUPORTADO: 122 kg
TOTAL WEIGHT SUPPORTED: 122 kg
PESO TOTAL SOPORTADO: 122 kg

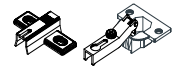
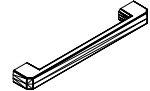
RELAÇÃO DE ACESSÓRIOS
LIST OF ACCESSORIES · LISTA DE ACCESORIOS

A 42  PARAFUSO FI CH PH 4,5x45 SCREW FI CH PH 4,5x45 TORNILLO FI CH PH 4,5x45	B 04  PUX. VERO 160mm HANDLE VERO 160mm TIRADOR VERO 160mm	C 02  PARAFUSO FI CH PH 4,0x25 SCREW FI CH PH 4,0x25 TORNILLO FI CH PH 4,0x25	D 24  PARAFUSO FI FL PH 3,5x30 SCREW FI FL PH 3,5x30 TORNILLO FI FL PH 3,5x30
E 18  CALÇO P/ DOBRA 5mm WEDGE FOR HINGE 5mm CALZO P/ BISAGRA 5mm	F 101  CAVILHA MADEIRA 6x25 WOOD PEG 6x25 TARUGO DE MADEIRA 6x25	G 42  PORCA CILINDRICA 12x09 CYLINDRICAL NUT 12x09 TUERCA CILINDRICA 12x09	H 20  CANTONEIRA METAL BRACKET METAL CANTONEIRA METAL
I 10  SAPATA LAT. MINI 12mm SHOE SIDE, MINI 12 mm SAPATA LAT. MINI 12mm	J 04  CUNHA WEDGE CUÑA	K 10  PREGO 12x12 NAIL 12x12 CLAVO 12x12	L 274  PREGO 10x10 NAIL 10x10 CLAVO 10x10
M 06  PORCA SX MA 4 NUT SX MA 4 TUERCA SX MA 4	N 06  SUPORE CABIDEIRO OB. HANGER HOLDER SOPORTE PARA PERCHERO	O 50  FIXADOR FUNDO BACKBOARD'S FIXER FIJADOR DEL COSTADO	P 18  DOBRA METAL 26mm METAL HINGE 26mm BISAGRA METAL 26mm
Q 04  CORREDIÇA TELESÓPICA TELESCOPIC SLIDES RIELES TELESÓPICO	R 18  PARAFUSO FI CH PH 3,5x40 SCREW FI CH PH 3,5x40 TORNILLO FI CH PH 3,5x40	S 06  PARAFUSO MQ PN ZB 4x25 SCREW MQ PN ZB 4x25 TORNILLO MQ PN ZB 4x25	T 130  PARAFUSO FI CH PH 4,0x12 SCREW FI CH PH 4,0x12 TORNILLO FI CH PH 4,0x12
U 02  COLA PVA GLUE PVA COLA PVA	V 02  PINO GIROFIX 35mm GIROFIX PIN 35mm TORNILLO DEL GIROFIX 35mm	W 02  CASTANHA GIROFIX 12x09 MINIFIX 12x09 MINIFIX 12x09	X 06  DOBRA 26mm C/CALÇO HINGE 26mm WITH WEDGE BISAGRA 26mm C/CALZO
Y 08  PUX. VERO 256mm HANDLE VERO 256mm TIRADOR VERO 256mm	Z 48  PARAFUSO FI CH PH 4,0x14 SCREW FI CH PH 4,0x14 TORNILLO FI CH PH 4,0x14		

RELAÇÃO DE PEÇAS
LIST OF PARTS • LISTA DE PARTES

DESCRIÇÃO DESCRIPTION DESCRIPCIÓN	VOLUME VOLUME VOLUMEM	NÚMERO NUMBER NÚMERO	DIMENSÃO DIMENSION DIMENSIÓN	QUANTIDADE QUANTITY CANTIDAD
PERFIL H H PROFILE PERFIL H	01	04	2035mm	01
VISTA SUPERIOR SUPERIOR FRONTAGE VISTA SUPERIOR	01	05	2120x73x15	01
VISTA CENTRAL CENTRAL FRONTAGE VISTA CENTRAL	01	06	1050x73x15	01
TAMPO/BASE COVER TAPA	01	3334	515x448x12	02
VISTA INFERIOR BOTTON FRONTAGE VISTA INFERIOR	01	3967	2120x73x15	01
TAMPO COVER TAPA	01	4694	515x300x12	01
LAT. EXT. ESQUERDA LEFT EXTERNAL SIDE LAT. EXT. IZQUIERDA	01	8276	2176x448x12	01
LAT. EXT. DIREITA RIGHT EXTERNAL SIDE LATERAL EXTERNA DERECHA	01	8332	2176x448x12	01
DIVISORIA DIVISION DIVISION	01	9916	497x448x12	01
DESCRIÇÃO DESCRIPTION DESCRIPCIÓN	VOLUME VOLUME VOLUMEM	NÚMERO NUMBER NÚMERO	DIMENSÃO DIMENSION DIMENSIÓN	QUANTIDADE QUANTITY CANTIDAD
TRASEIRO G.R WARDROBE'S BACKBOARD COSTADO DEL RÓPERO	02	02	2043x524x2,5	02
TRASEIRO G.R WARDROBE'S BACKBOARD COSTADO DEL RÓPERO	02	03	2034x530x2,5	02
TRAVA LOCK TRABA	02	5947	515x50x12	02
FRENTE GAVETA DRAWER'S FRONT FRENTE DEL CAJÓN	02	7154	523x170x15	04
PORTA DOOR PUERTA	02	8289	2018x260x15	04
PORTA DOOR PUERTA	02	8290	1576x256x15	04
BATENTE TOP SUPPORT BATIENTE	02	8365	356x90x12	01

RELAÇÃO DE PEÇAS
LIST OF PARTS • LISTA DE PARTES

DESCRIÇÃO DESCRIPTION DESCRIPCIÓN	VOLUME VOLUME VOLUMEM	NÚMERO NUMBER NÚMERO	DIMENSÃO DIMENSION DIMENSIÓN	QUANTIDADE QUANTITY CANTIDAD
CABIDEIRO ECO. FRIZADO FRIZZED ECO HANGER PERCHERO ECO. FRIZADO	03	07	506mm	03
FUNDO GAVETA DRAWER'S BOTTOM FONDO DEL CAJÓN	03	08	488x365x2,5	04
RODAPÉ FRONT/TRAS BASEBOARD FRONT/BACK ZÓCALO FRONTAL/TRASERO	03	3966	515x71x12	06
TRASEIRO GAVETA DRAWER'S BACKBOARD TRASERO DE CAJÓN	03	7157	466x90x12	04
TAMPO COVER TAPA	03	7851	515x380x12	01
CHAPÉU WARDROBE'S TOP TAPA SUPERIOR	03	8333	2096x448x12	01
LAT.INTERNA CENTRAL CENTRAL INTERNAL SIDE LAT. INTERNA CENTRAL	03	8336	1216x380x12	01
TAMPO DA GAVETA DRAWER'S COVER TAPA DEL CAJÓN	03	8337	1042x448x12	01
BASE MALEIRO BASE FOR LUGGAGE RACK BASE DEL PORTAEQUIPAJES	03	8338	1042x380x12	01
TAMPO COVER TAPA	03	8339	515x380x12	03
PRATELEIRA SHELF ESTANTE	03	8353	515x380x12	02
LAT. DE GAVETA SIDE DRAWER LATERAL DE CAJÓN	03	9426	357x101x12	08
LAT.INTERNA ESQUERDA LEFT INTERNAL SIDE LAT. INTERNA IZQUIERDA	03	9914	2093x448x12	01
LAT.INTERNA DIREITA RIGHT INTERNAL SIDE LAT. INTERNA DERECHA	03	9915	2093x448x12	01

**Ps: Peças e Complementos que não contém processo de furação não são enumeradas.
Parts and Accessories that do not contain drilling process and are not listed.
Piezas y Accesorios que no contienen procesos de perforación y que no numerados.**

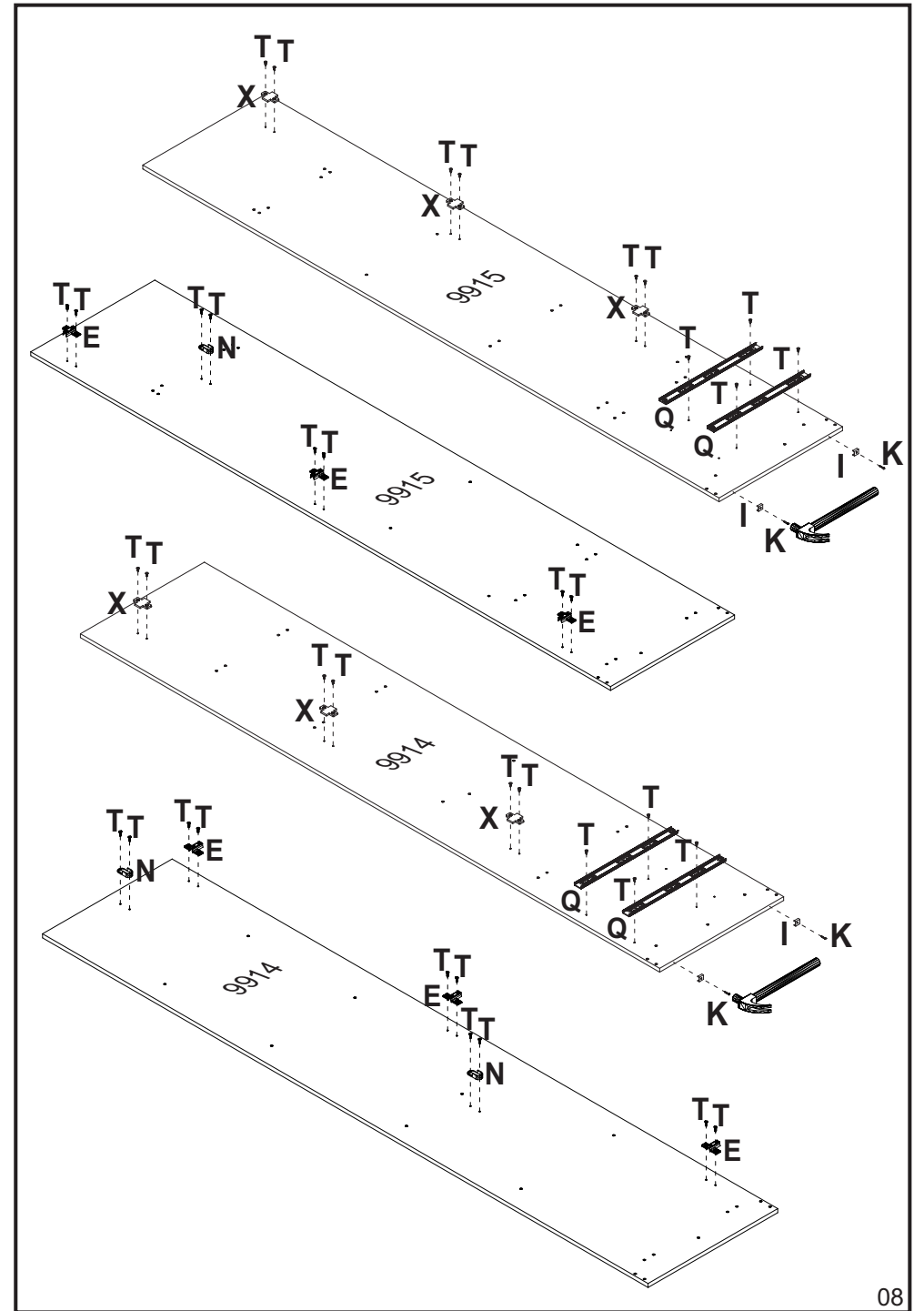
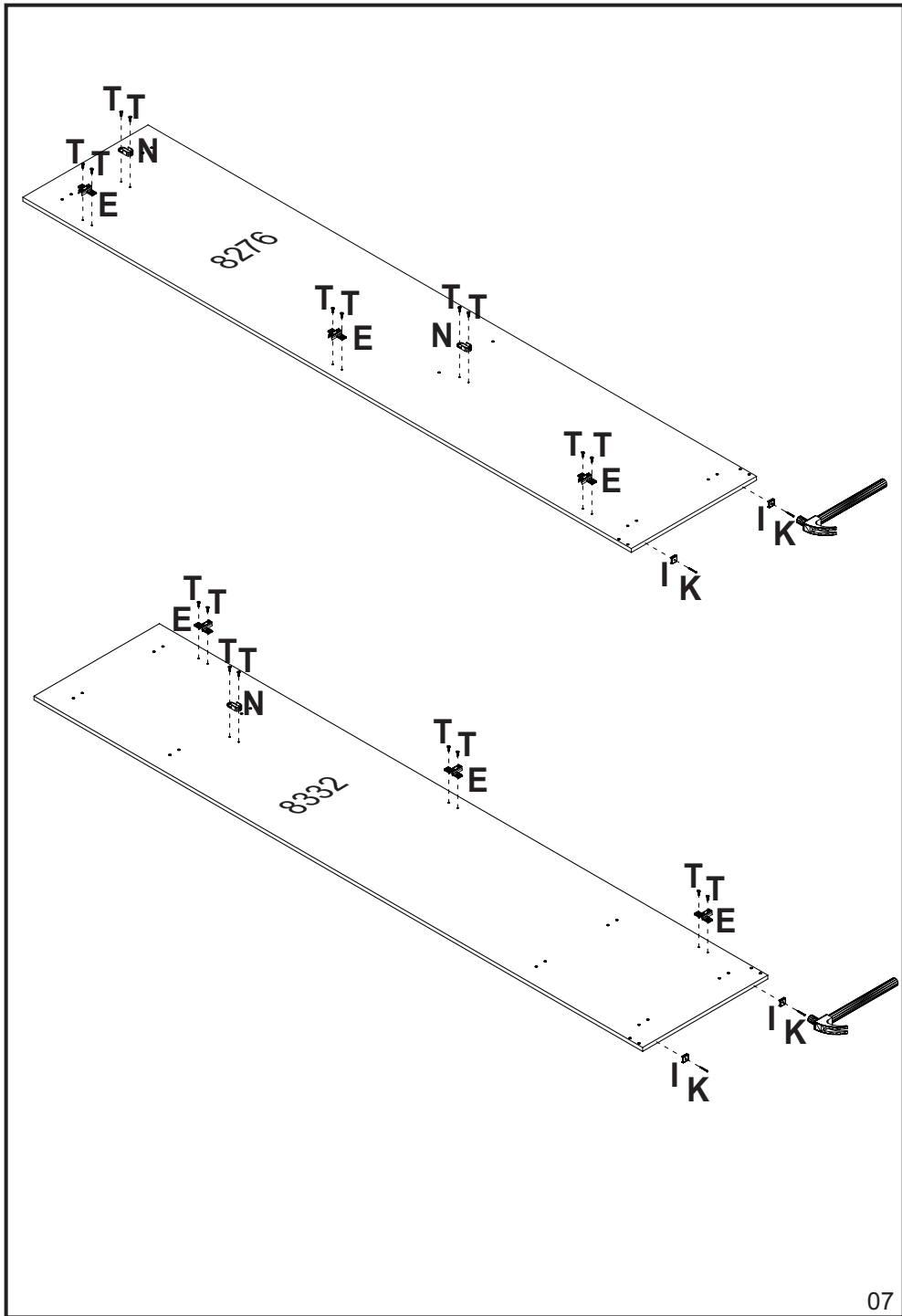

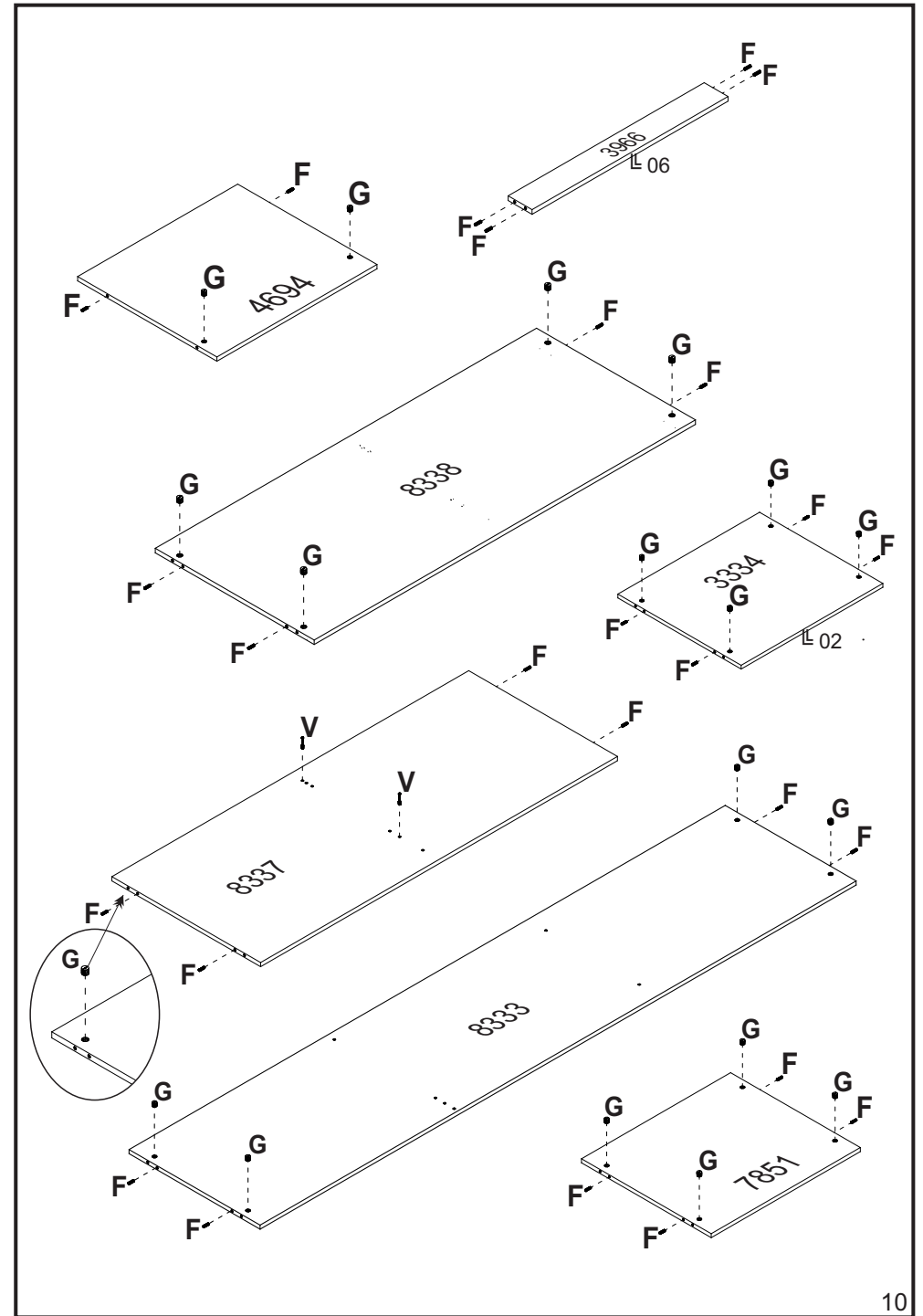
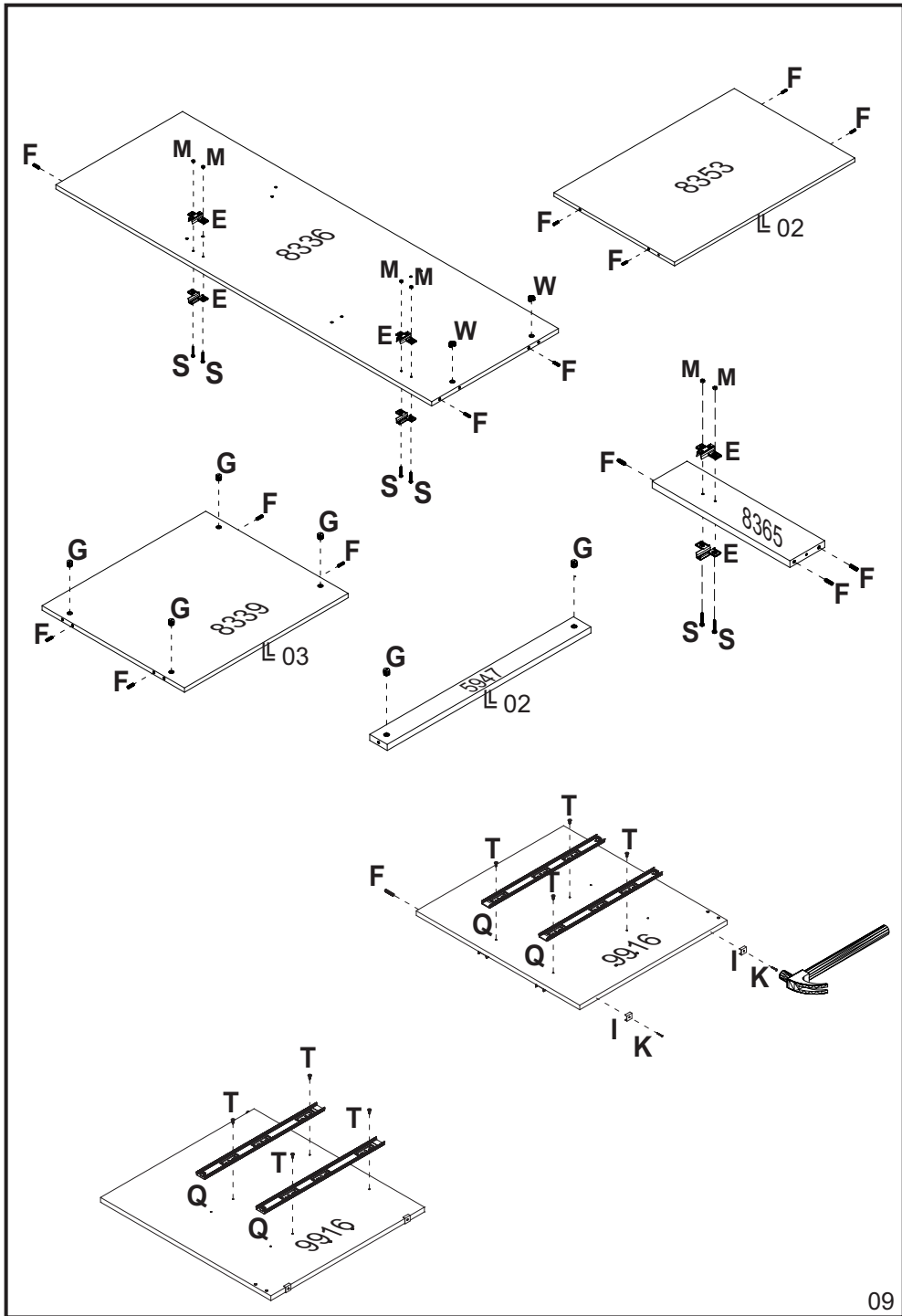

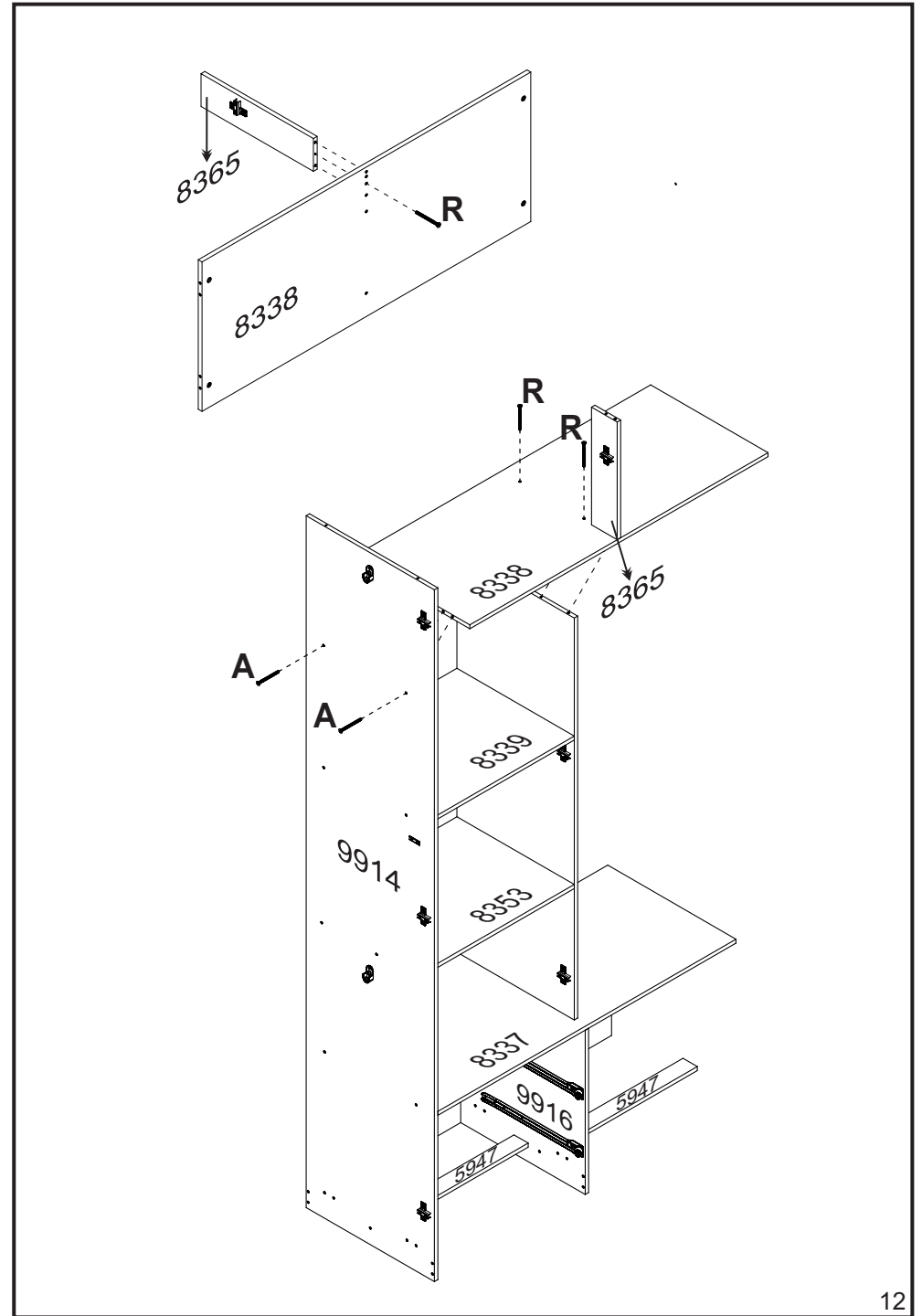
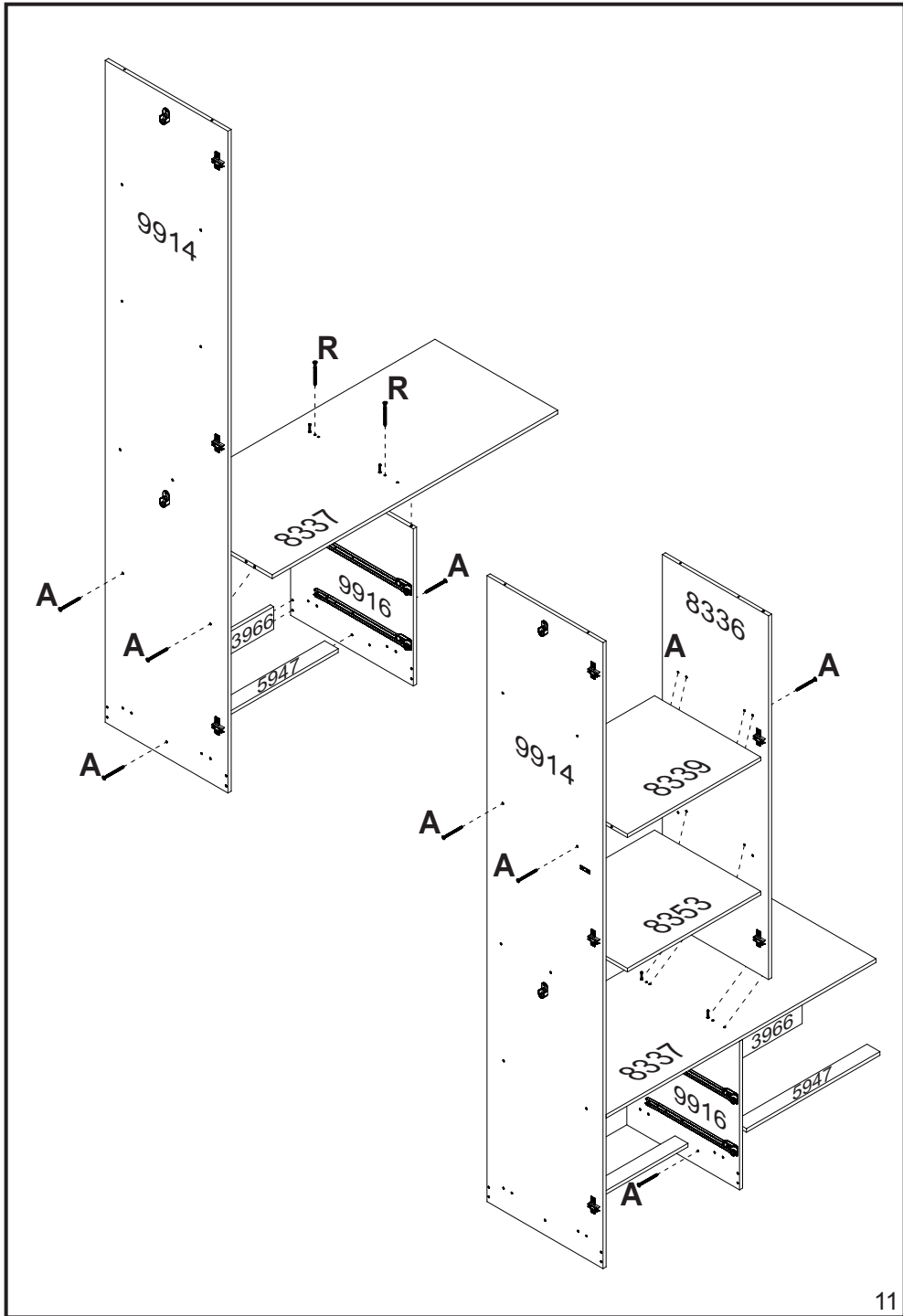

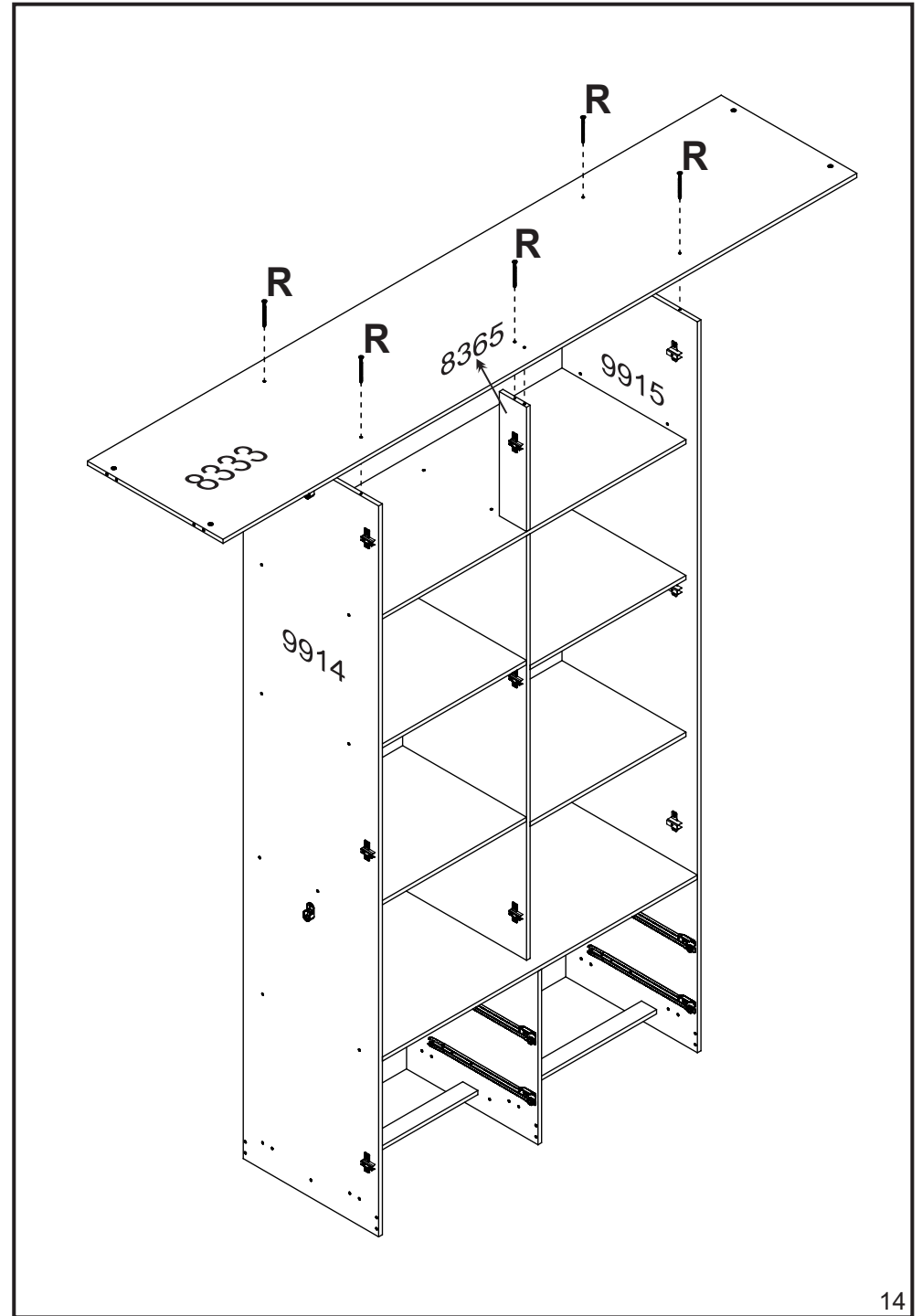
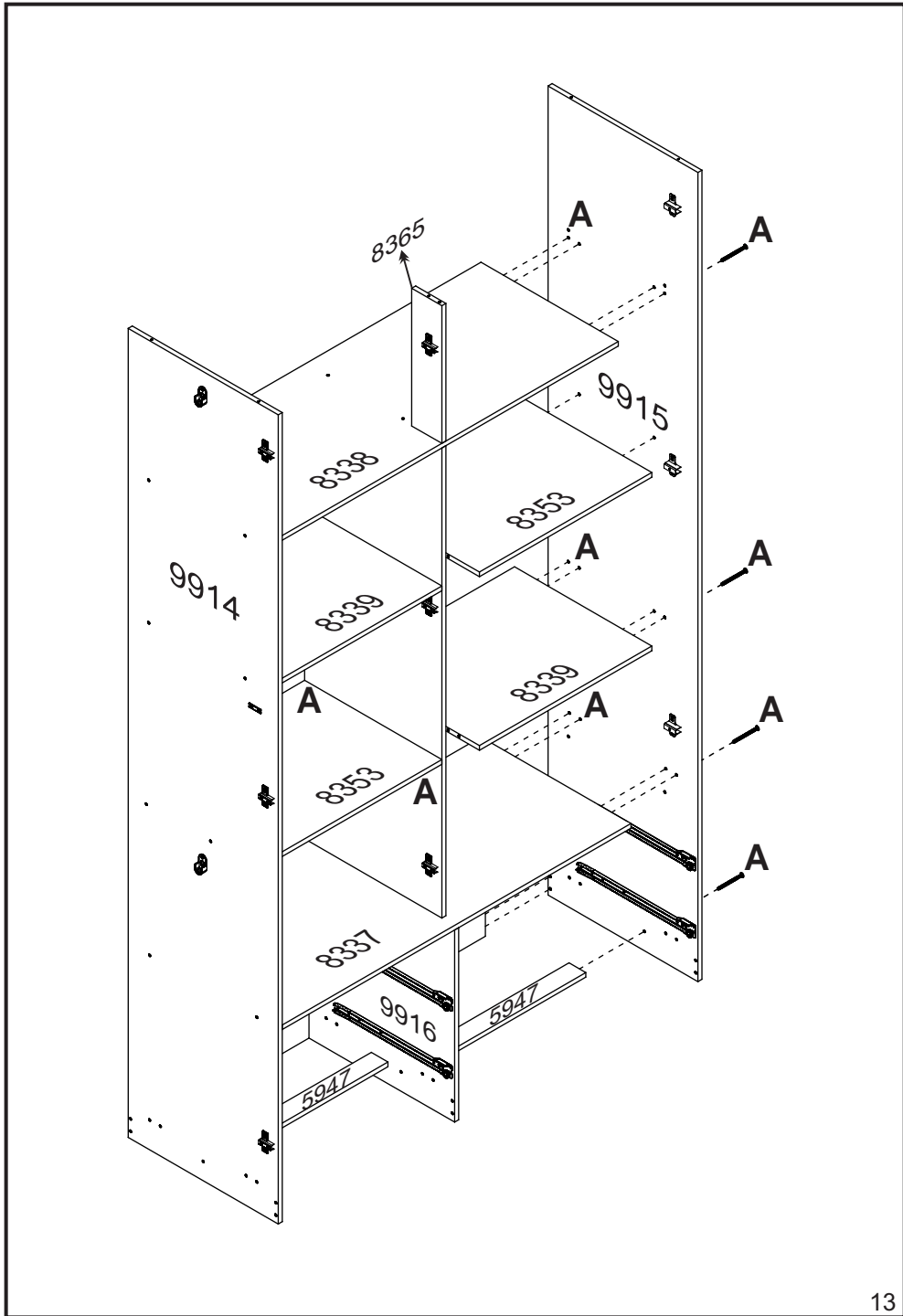

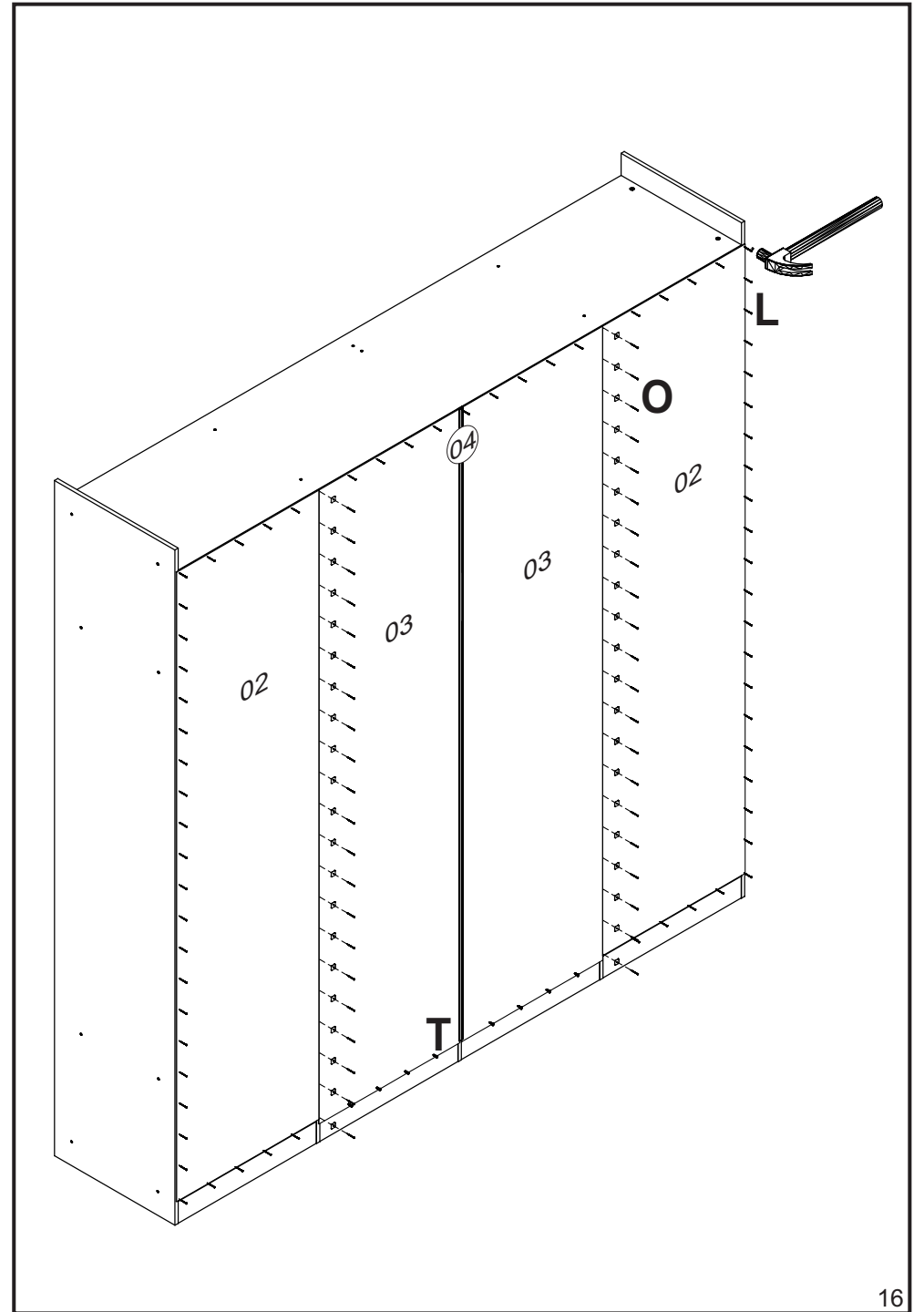
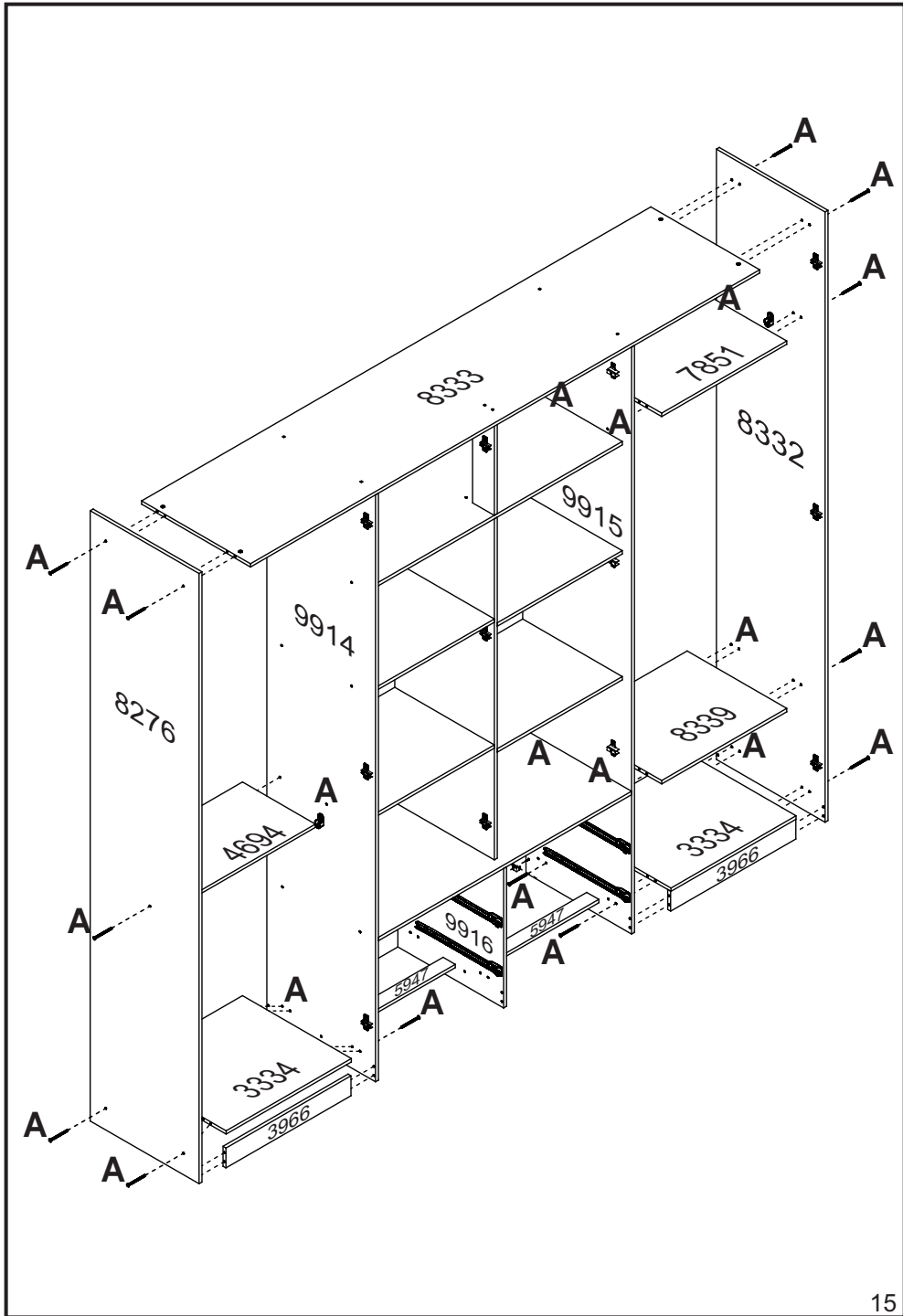

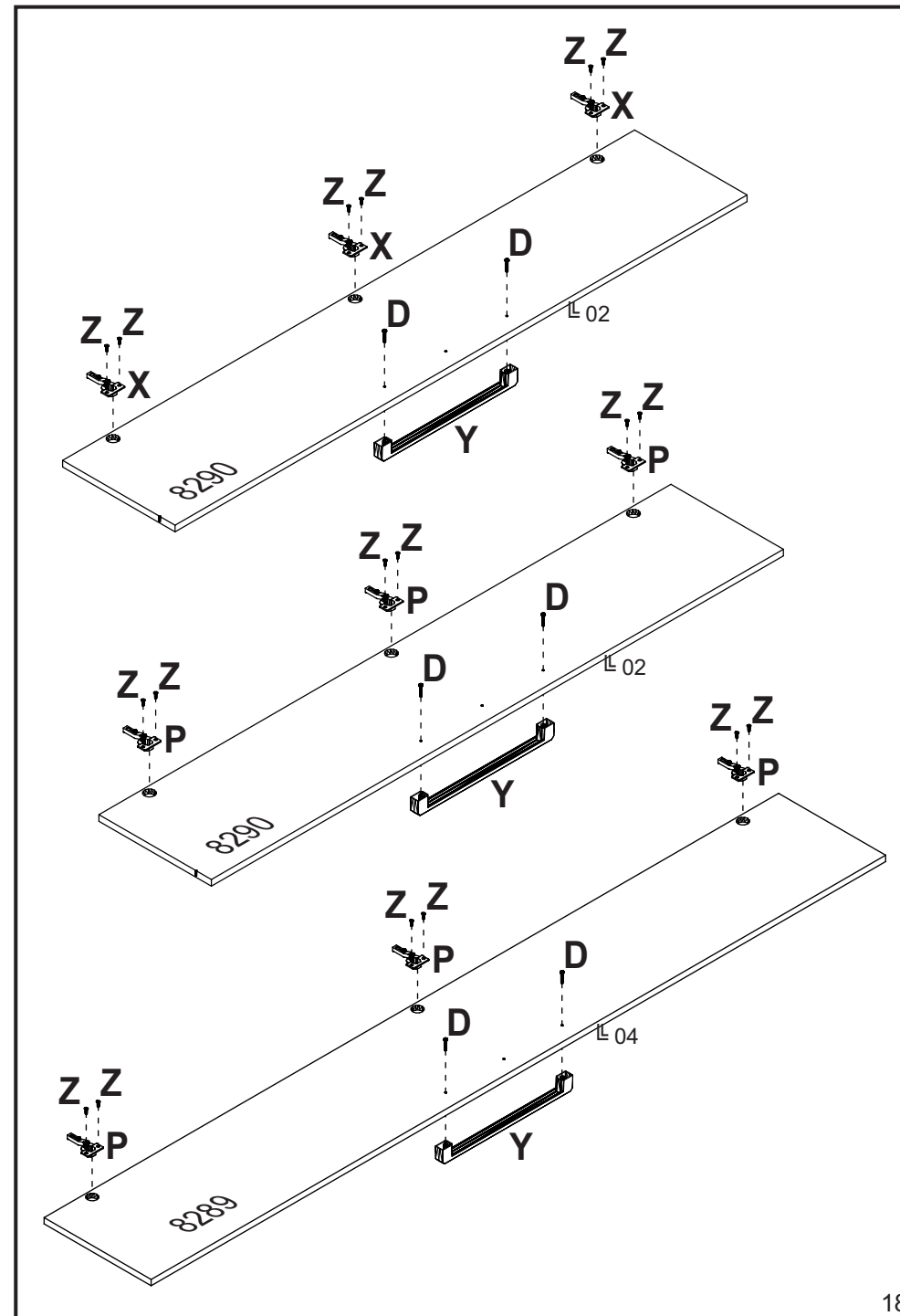
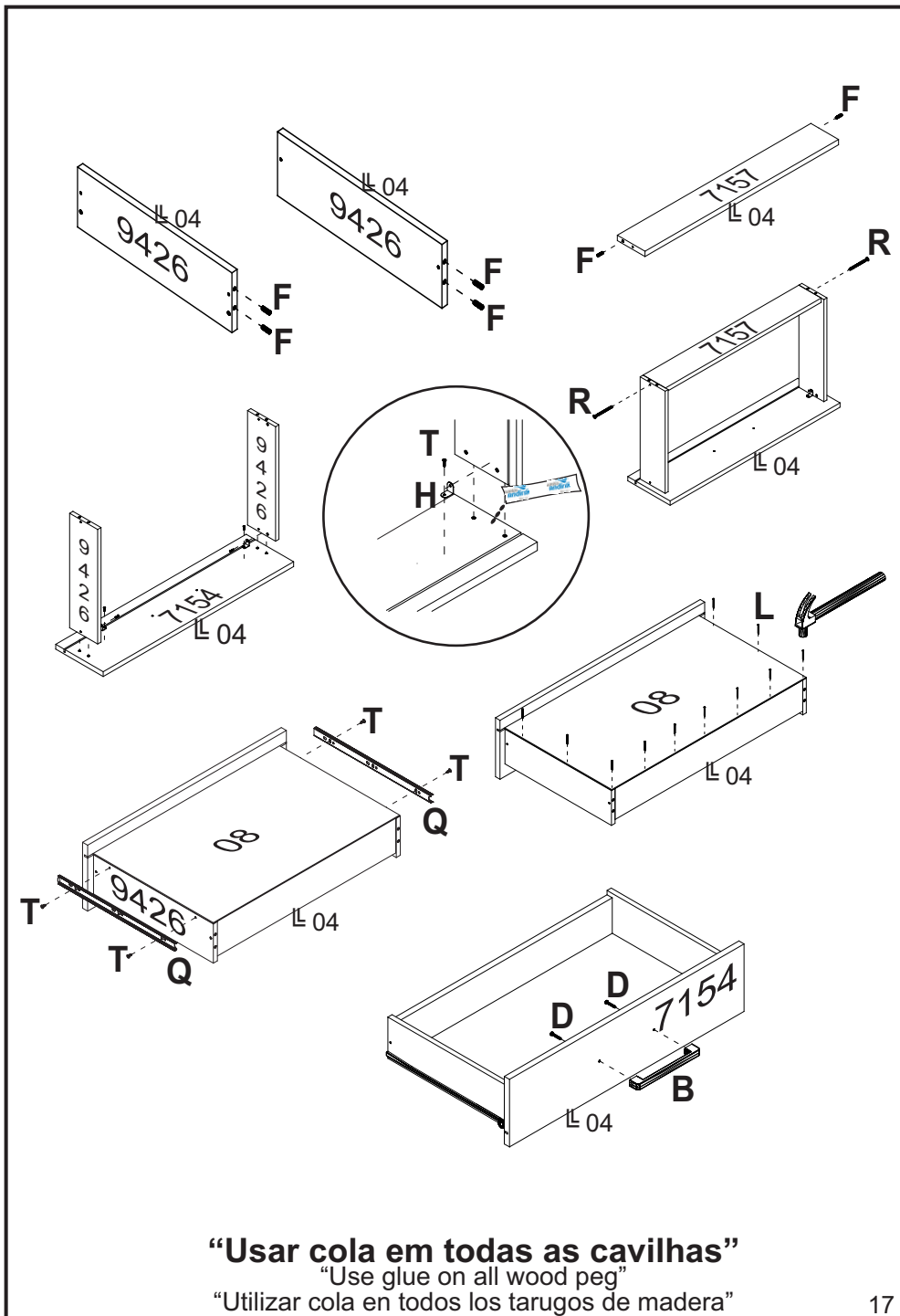

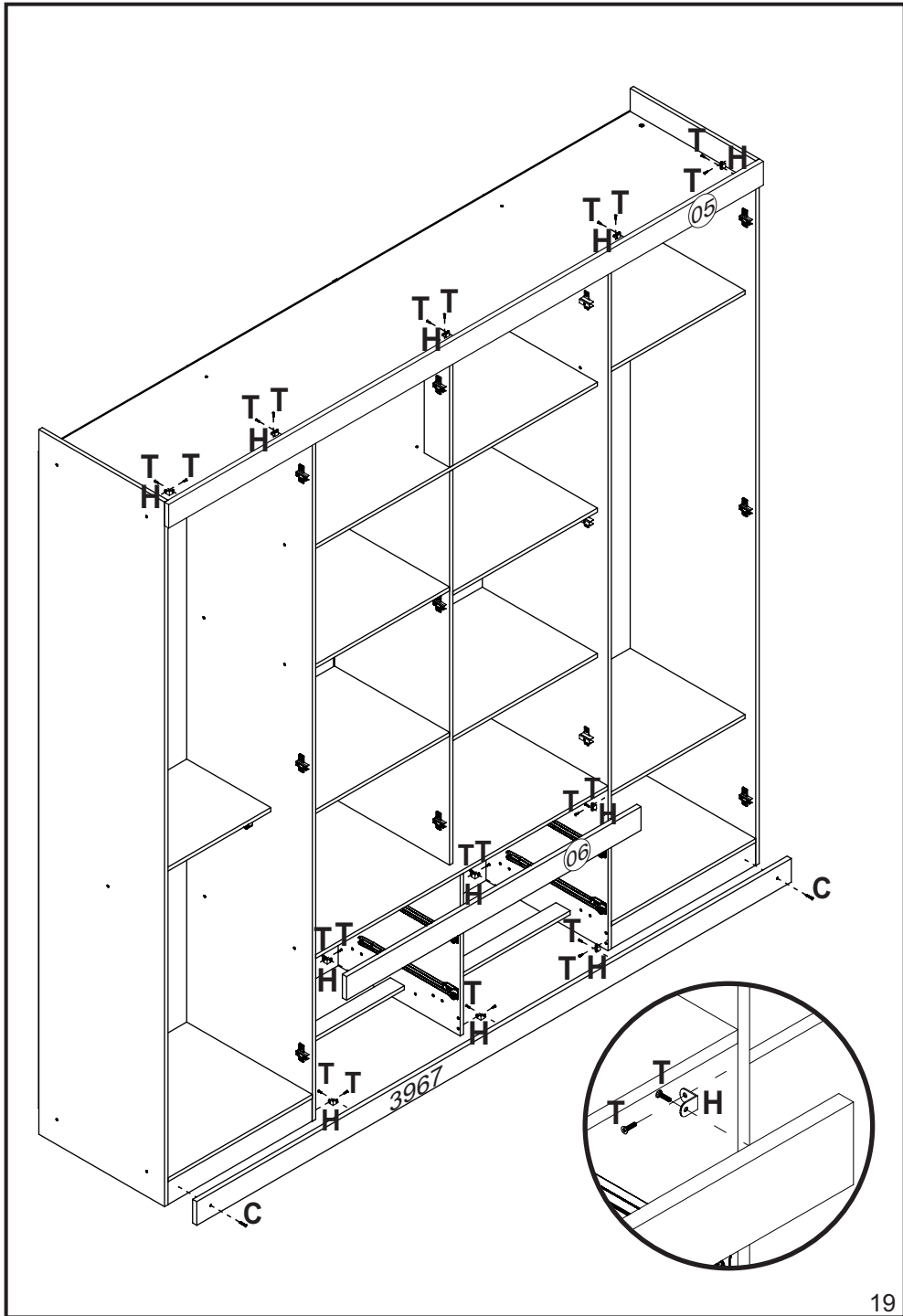

MEDIDA DO PRODUTO MONTADO
 MEASURE OF THE ASSEMBLED PRODUCT
 MEDIDA DEL PRODUCTO ENSAMBLADO

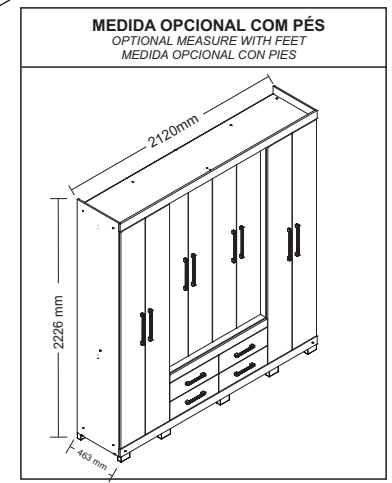
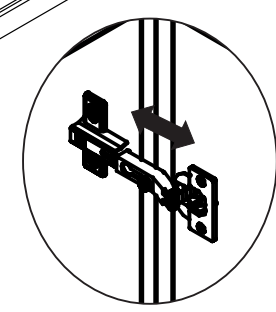
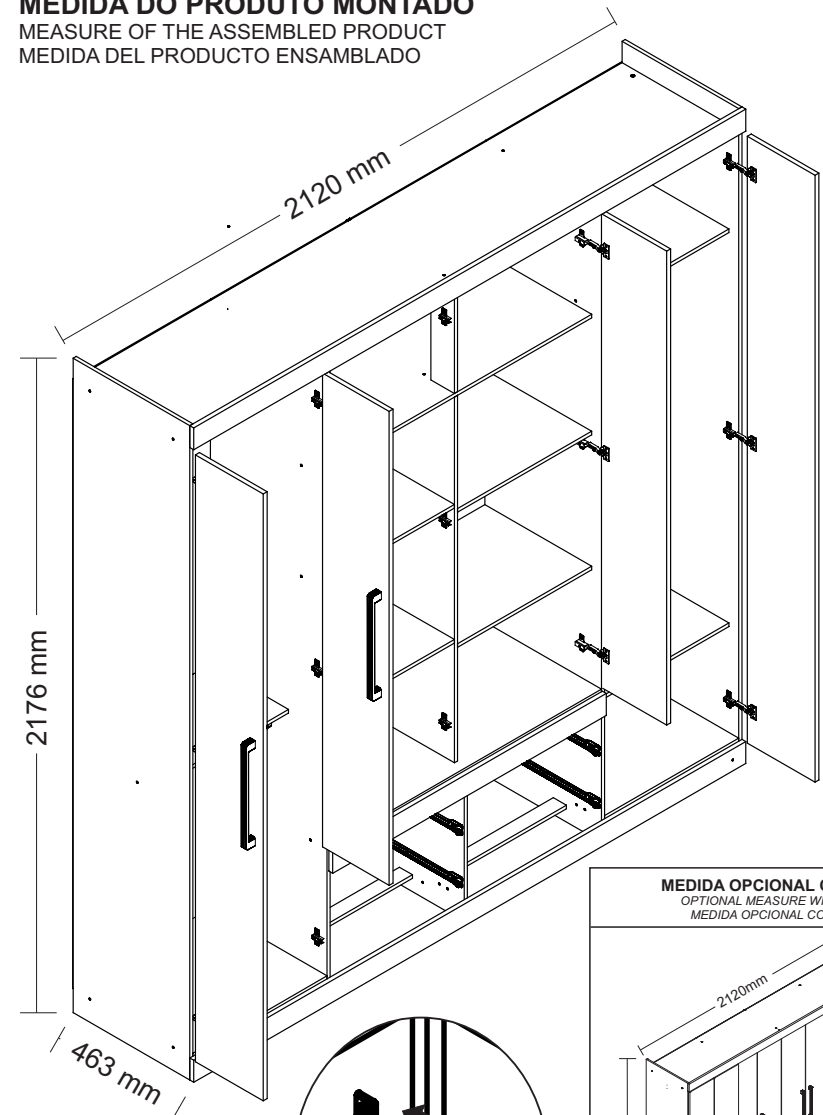

☎ +55 (43)3538-8300